

## FEATURES

- Portable to any job site having compressed air.
- Superior reliability – Designed using minimal parts for maximum reliability.
- Balance of toughness and weight - A lightweight, compact design made using durable heavy-duty anodized aluminum provides toughness while reducing overall weight.
- All weather performance – Seals and other components selected for best performance over a temperature range of -35F to 250F.
- Utilizes a 360 degree swivel hose connector for increased flexibility to work in any position
- Exclusive “air-thrust” design rapidly takes up slack, putting the cylinder rod or tool in its work position very quickly.



This versatile air pump can safely deliver up to 10,000 psi of hydraulic pressure for a variety of applications. When an air supply is available at your job site, it is quick and easy to use this air pump and it reduces operator fatigue over the use of a manual pump.

Hydraulic Pressure (psi) at 100 PSI	Oil Volume
-	200
20	60
2,000	40
3,000	38
4,000	32
5,000	30
6,000	28
7,000	26
8,000	20
9,000	16
10,000	12

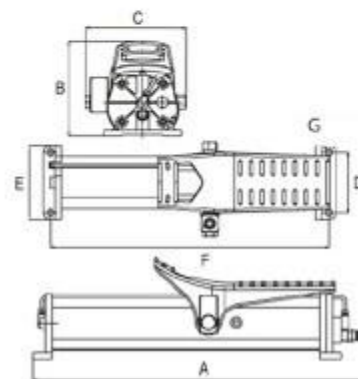

### STA-40 Air Pump

Model Number	Oil Capacity (in3)	Pressure Rating (psi)	Output Flow Rate (in3/m in.)		Air Pressure Range	Dimensions (in.)						Oil Port (in)	Ship Weight (lbs)
			Load	Load		A	B	C	D	E	F		
STA-40	37	10,000	215	12	40-140	18.14	5.51	5.70	3.54	4.33	15.98	3/8" NTP	15